

# REVÍZNA ŠACHTA

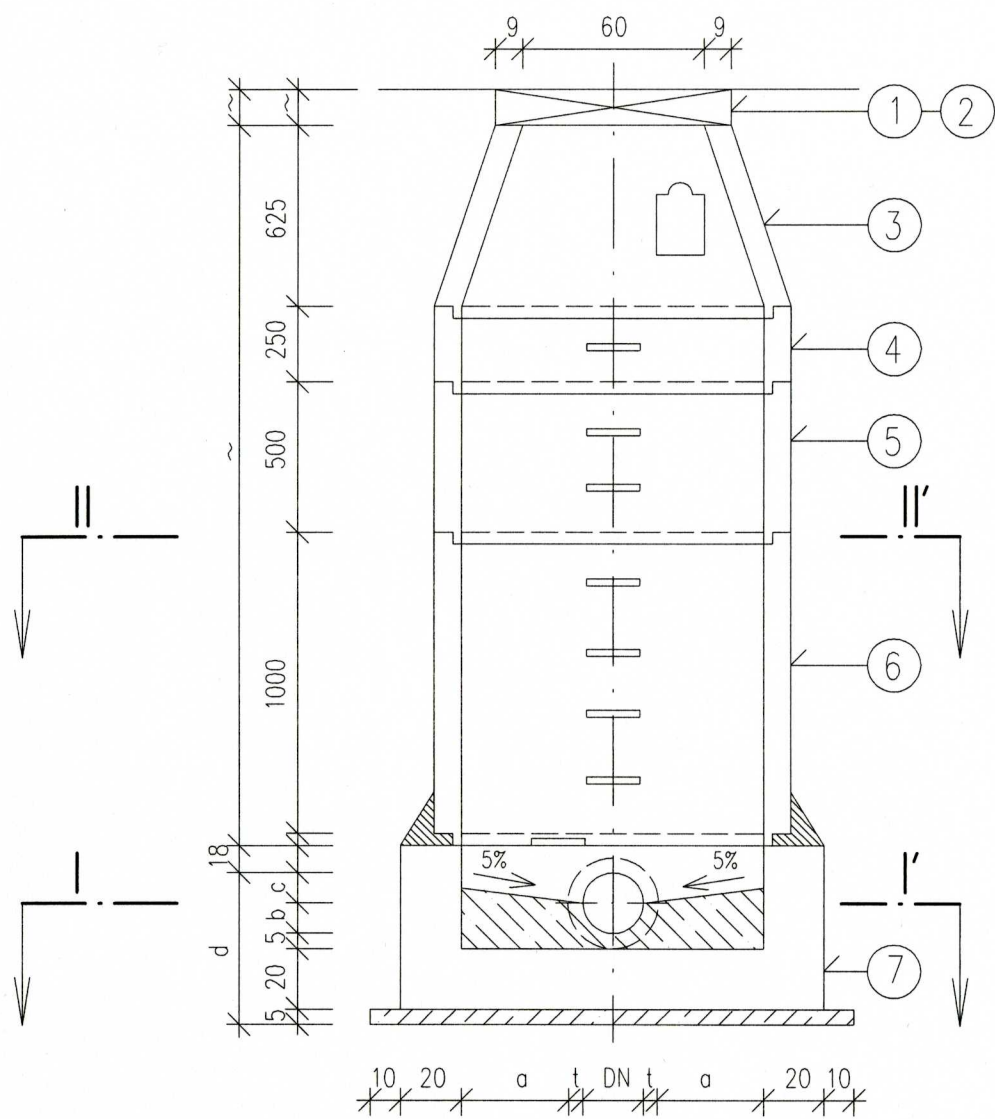

OZNAČENIE	POPIS
1	LIATINOVÝ POKLOP "B,D"
2	VYROVNÁVACÍ PRSTENEC TBS-625/60, 80, 100
3	BETÓNOVÝ DIEL TBS-1000/625-S
4	BETÓNOVÝ DIEL TBS-1000/250-S
5	BETÓNOVÝ DIEL TBS-1000/500-S
6	BETÓNOVÝ DIEL TBS-1000/1000-S
7	PREFABRIKOVANÉ ŠACHTOVÉ DNO SD 1000

DN	a	b	c	d
	cm			
150	42,5	10,5	4,5	40,0
200	40,0	13,0	7,0	45,0
250	37,5	15,5	9,5	50,0
300	35,0	18,0	12,0	55,0
400	30,0	23,0	17,0	65,0
500	25,0	28,0	22,0	75,0
600	20,0	33,0	27,0	85,0